



MONMOUTH SOLUTIONS PROPOSAL

UEI: E474YENAVPB7
CAGE: 9DMG0
SDVOSB CERT #:
VSBC-52457208749



About Us

Monmouth Solutions, Inc is a Service-Disabled Veteran Owned Small Business that was formed in 2022 with a focus on logistical coordination, metal/steel manufacturing, equipment rentals, trailer and vehicle sales, and much more. As a veteran owned business, we know firsthand how important it is for vendors to offer efficient and effective products and services to the government. The founders of Monmouth consist of industry leaders with almost a century of combined experience. Using our diverse team of experts, we have been able to successfully complete over 100 contracts for state, local, and federal government agencies since inception.

Core Competencies

Equipment Lease

- Heavy Equipment
- Material Handling
- Rental Vehicles
- Mobile Structures

Trailer Manufacturing

- Travel Trailers
- Command/Hazmat Trailers
- Pressure Washer/Sprayer Trailers
- Dump, Flatbed, Gooseneck, Enclosed, ETC

Disaster Relief

- Rapid Deployment
- Logistical Support
- Product Sourcing

Lodging & Travel

- Hotel Sourcing
- Transportation Solutions
- Charters

Equipment & Vehicle Sales

- Computer and IT Parts and Services
- Recreational Vehicles
- Heavy Equipment

NAICS

336212 Truck Trailer Manufacturing

532412 Construction, Mining, and Forestry Machinery and Equipment Rental and Leasing

532490 Other Commercial and Industrial Machinery and Equipment Rental and Leasing

335311 Power, Distribution, and Specialty Transformer Manufacturing

336214 Travel Trailer and Camper Manufacturing

532111 Passenger Car Rental

441210 Recreational Vehicle Dealers

332439 Other Metal Container Manufacturing

334111 Electronic Computer Manufacturing

333924 Industrial Truck, Tractor, Trailer, and Stacker Machinery Manufacturing

811310 Commercial and Industrial Machinery and Equipment (Except Automotive and Electronic) Repair and Maintenance

336211 Motor Vehicle Body Manufacturing

333120 Construction Machinery Manufacturing

333310 Commercial and Service Industry Machinery Manufacturing

721110 Hotels (except Casino Hotels)

337000 Furniture and Related Product Manufacturing.

Monmouth Solutions

PROPOSAL

Genie GS-1930 Scissor Lift - Anthony Correctional Center

**SOLICITATION# ARFQ 0608
DCR2500000020**

Monmouth Solutions will provide and deliver one (1) new Genie GS-1932 or new Genie GS-1932 Micro that meets the attached specifications to 313 Anthony Center Drive, White Sulphur Springs, WV 24986.

Please refer to Specifications and Technical Data below.

UEI: E474YENAVPB7
CAGE: 9DMG0
SDVOSB CERT #: VSBC-52457208749



Company Overview:

Monmouth Solutions, Inc. stands as a beacon of reliability and innovation in the government procurement sector. Our core values of integrity, efficiency, and customer satisfaction drive every facet of our operations. As a certified SDVOSB, we take pride in our ability to provide exceptional solutions while simultaneously fostering opportunities for veterans in the workforce.

Key Strengths:

Strategic Partnerships: We have cultivated strong relationships with suppliers globally, enabling us to procure the highest quality equipment and services for our clients.

Nationwide Coverage: With strategic locations and a robust fleet, we offer unparalleled coverage and rapid response times, ensuring timely delivery and service.

Veteran-Led Expertise: Our leadership team, comprised of veterans, brings a wealth of experience and dedication to every project we undertake.

Commitment to Excellence: We adhere to the highest standards of quality control and service delivery, ensuring that every client receives nothing but the best.

Services Offered:

Equipment Procurement: We specialize in sourcing a wide range of equipment, from technology to machinery, tailored to meet the specific needs of government agencies.

Logistics and Delivery: Leveraging our extensive fleet and logistics expertise, we provide efficient and reliable delivery services to ensure timely fulfillment of orders.

Consulting and Support: Our team of experts offers comprehensive consulting services, guiding clients through the procurement process and providing ongoing support to ensure optimal performance of acquired assets.

Contract Specific Company Data

Monmouth Solutions, Inc. offers a comprehensive list of machinery tailored to the specific needs of government agencies. Our strategic locations across the country and extensive fleet ensure rapid deployment and reliable support for all heavy, compact, aerial, and material handling equipment requirements.

Key Strengths:

Extensive Fleet: With a fleet of over 25 trucks managed by our sister company, we offer nationwide coverage and rapid deployment capabilities for all equipment needs.

Top-Tier Equipment: We provide access to a diverse range of high-quality machinery, including loaders, boomlifts, and more, sourced from trusted suppliers worldwide.

Proven Track Record: With a history of successful execution on similar equipment contracts, our demonstrated performance speaks volumes. Our track record showcases our ability to handle projects of varying complexities efficiently and effectively.

Customization Expertise: Whether it's standard lift models or compact units with custom designs tailored to specific needs, our team has the expertise to deliver. We understand that every project is unique, and we excel in crafting solutions that meet or exceed expectations.





A TEREX BRAND

Self-Propelled Scissor Lifts

GS™ -1530, GS-1930 & GS-1932

Specifications

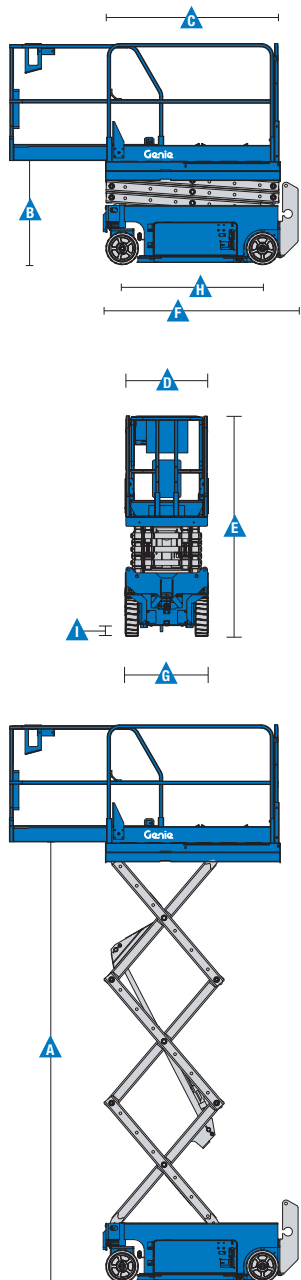

Models	GS-1530		GS-1930		GS-1932	
Measurements	US	Metric	US	Metric	US	Metric
Working height maximum - indoor ¹	21 ft	6.57 m	25 ft 3 in	7.79 m	25 ft 3 in	7.85 m
- outdoor ¹	19 ft 6 in	6.11 m	20 ft 8 in	6.47 m	20 ft 8 in	6.47 m
A Platform height maximum - indoor	15 ft 1 in	4.61 m	19 ft 3 in	5.85 m	19 ft 3 in	5.85 m
- outdoor	13 ft 6 in	4.11 m	14 ft 8 in	4.47 m	14 ft 8 in	4.47 m
B Platform height stowed	3 ft 2 in	.97 m	3 ft 4 in	1.00 m	3 ft 4 in	1 m
C Platform length - outside	5 ft 4 in	1.63 m	5 ft 5 in	1.66 m	5 ft 5 in	1.66 m
extended	8 ft 4 in	2.54 m	8 ft 5 in	2.55 m	8 ft 5 in	2.55 m
Roll-out platform extension deck	3 ft	0.91 m	3 ft	0.91 m	3 ft	0.91 m
D Platform width - outside	29.9 in	0.76 m	29.9 in	0.76 m	29.9 in	0.76 m
Guardrail height	3 ft 7 in	1.1 m	3 ft 7 in	1.1 m	3 ft 7 in	1.1 m
Toeboard height	6 in	15 cm	6 in	15 cm	6 in	15 cm
E Height-stowed: folding rails	6 ft 10 in	2.08 m	6 ft 11 in	2.12 m	6 ft 11 in	2.12 m
rails folded	5 ft 8 in	1.72 m	5 ft 9 in	1.76 m	5 ft 9 in	1.76 m
F Length-stowed	6 ft	1.83 m	6 ft	1.83 m	6 ft	1.83 m
Length-stowed extended	8 ft 11 in	2.74 m	8 ft 11 in	2.74 m	8 ft 11 in	2.72 m
G Width	2 ft 6 in	0.76 m	2 ft 6 in	0.76 m	2 ft 8 in	0.82 m
H Wheelbase	4 ft 4 in	1.32 m	4 ft 4 in	1.32 m	4 ft 4 in	1.32 m
I Ground clearance-center	2.4 in	6 cm	2.4 in	6 cm	2.4 in	6 cm
- with pothole guards deployed	0.75 in	2 cm	0.75 in	2 cm	0.75 in	2 cm

Productivity

Maximum platform occupancy (in/out)	2/1		2/1		2 / 1	
Lift capacity	600 lbs	272 kg	500 lbs	227 kg	500 lbs	227 kg
Lift capacity - extension deck	250 lbs	113 kg	250 lbs	113 kg	250 lbs	113 kg
Drive height	full height		full height		full height	
Drive speed - stowed	2.5 mph	4.0 km/h	2.5 mph	4.0 km/h	2.5 mph	4.0 km/h
Drive speed - raised	0.5 mph	0.8 km/h	0.5 mph	0.8 km/h	0.5 mph	0.8 km/h
Gradeability - stowed ²	30%		25%		25%	
Turning radius - inside	zero		zero		zero	
Turning radius - outside	5 ft 1 in	1.55 m	5 ft 1 in	1.55 m	5 ft 1 in	1.55 m
Raise / lower speed	16 / 22 sec		16 / 22 sec		16 / 22 sec	
Tilt sensor activation - front to back	3°		3°		3°	
- side to side	1.5°		1.5°		1.5°	
Controls	proportional		proportional		proportional	
Drive	dual front wheel		dual front wheel		dual front wheel	
Multiple disc brakes	dual rear wheel		dual rear wheel		dual rear wheel	
Tires - solid non-marking	12 x 4.5 in	30.5 x 11.5 cm	12 x 4.5 in	30.5 x 11.5 cm	12 x 4.5 in	30.5 x 11.5 cm

Power

Power source	24 V DC (four 6 V 225 Ah batteries)					
Hydraulic system capacity	3.8 gal	14.2 L	3.8 gal	14.2 L	3.8 gal	14.2 L

Weight³ / Floor Loading⁴

Weight - ANSI, CSA	2,817 lbs	1,278 kg	3,318 lbs	1,505 kg	2,999 lbs	1,360 kg
Tire load, maximum	1,322 lbs	600 kg	1,460 lbs	662 kg	1,435 lbs	651 kg
Tire contact pressure	147 psi	1,013 kPa	162 psi	1,118 kPa	159 psi	1,099 kPa
Occupied floor pressure	254 psf	12.17 kPa	284 psf	13.6 kPa	244 psf	11.69 kPa

Standards Compliance ANSI A92.20, CSA B354.6, CE EN280, AS 1418.10



Self-Propelled Scissor Lifts

GS™ -1530, GS-1930 & GS-1932

Features

Standard Features	Standard Features	Options & Accessories
-------------------	-------------------	-----------------------

Measurements

GS-1530

- 21 ft 1 in (6.61 m) working height
- Up to 600 lbs (272 kg) lift capacity

GS-1930

- 25 ft 3 in (7.85 m) working height
- Up to 500 lbs (227 kg) lift capacity

GS-1932

- 25 ft 3 in (7.85 m) working height
- Up to 500 lbs (227 kg) lift capacity

Productivity

- 64 x 29 in (1.63 x .74 m) steel platform
- Folding rails with half-height swing gate
- 36 in (.91 m) extension deck
- Drive at full height
- Dual front wheel drive
- SmartLink™ - dual zone control
- Proportional lift and drive
- Platform load sense system
- Platform control guard
- Universal 27A smart charger
- Rear recessed charger receptacle
- Up to 30% gradeability
- Platform control with battery charge indicator and diagnostic display
- On-board diagnostic system
- AC power to platform
- Lanyard attachment points
- Manual platform lowering valve
- Emergency stop at both platform and ground controls
- Rear wheel multiple disc brakes
- Front wheel hydraulic dynamic braking
- Manual hydraulic brake release
- Swing-out component trays
- Solid non-marking tires
- Pothole guards
- Tilt level sensor with audible alarm
- Dual flashing LED beacons

Productivity (continued)

- Descent alarm
- Electronic horn
- Hour meter
- Motion alarm
- Lift Connect™ Telematics
- Tech Pro™ Link compatible

Power

- 24 V DC (four 6 V 225 Ah batteries)

Productivity Options

- Air line to platform
- Automotive horn*
- Biodegradable hydraulic fluid
- Lift Tools™ Pipe Cradle
- Lift Tools Panel Cradle
- Lift Tools Work Tray
- Lift Guard™ Contact Alarm

Power Options

- Power inverter (120 V/60 Hz)¹
- EE rating
- AGM maintenance-free batteries
- Drive cutout while charging



<< go back

¹ Not available with EE rating

Genie United States

6464 185th Ave. NE
 Redmond, WA 98052
 Telephone +1 (425) 881-1800
 Toll Free in USA/Canada +1 (800)-536-1800
 Fax +1 (425) 883-3475

Distributed By:



Effective Date: November, 2019. Product specifications and prices are subject to change without notice or obligation. The photographs and/or drawings in this document are for illustrative purposes only. Refer to the appropriate Operator's Manual for instructions on the proper use of this equipment. Failure to follow the appropriate Operator's Manual when using our equipment or to otherwise act irresponsibly may result in serious injury or death. The only warranty applicable to our equipment is the standard written warranty applicable to the particular product and sale and we make no other warranty, express or implied. Products and services listed may be trademarks, service marks or trade names of Terex Corporation and/or their subsidiaries in the USA and many other countries. Terex, Genie and AWP are registered trademarks of Terex Corporation or its subsidiaries. © 2019 Terex Corporation.

Genie® GS™ -1432m & GS-1932m

Specifications

Models	GS-1432m		GS-1932m	
	US	Metric	US	Metric
Measurements				
Working height max. - indoor ⁽¹⁾	20 ft 1 in	6.30 m	24 ft 2 in	7.55 m
Working height max. - outdoor ⁽¹⁾	18 ft	5.66 m	21 ft	6.57 m
A Platform height max. - indoor	14 ft 1 in	4.30 m	18 ft 3 in	5.55 m
A Platform height max. - outdoor	12 ft	3.66 m	15 ft	4.57 m
B Platform height - stowed	2 ft 6 in	0.77 m	2 ft 10 in	0.87 m
C Platform length - outside	4 ft 7 in	1.40 m	4 ft 7 in	1.40 m
C Platform length - outside, extended	6 ft 7 in	2.00 m	6 ft 7 in	2.00 m
Slide-out platform extension deck - length	2 ft	0.60 m	2 ft	0.60 m
D Platform width - outside	2 ft 6.5 in	0.78 m	2 ft 6.5 in	0.78 m
Guardrail height	3 ft 7 in	1.10 m	3 ft 7 in	1.10 m
Toeboard height	6 in	15 cm	6 in	15 cm
E Machine Height - stowed (fixed rails)	6 ft 2 in	1.88 m	6 ft 5 in	1.97 m
F Length machine - stowed	4 ft 7 in	1.40 m	4 ft 7 in	1.40 m
F Length machine - stowed, extended	6 ft 7 in	2.00 m	6 ft 7 in	2.00 m
G Width	32 in	0.81 m	32 in	0.81 m
H Wheelbase	3 ft 8 in	1.12 m	3 ft 8 in	1.12 m
I Ground clearance (center) - pothole guards retracted	2.8 in	7 cm	2.8 in	7 cm
I Ground clearance - pothole guards deployed	0.75 in	1.90 cm	0.75 in	1.90 cm

Productivity

Max. platform occupancy (in/out)	2/1		2/1	
Lift capacity	500 lb	227 kg	500 lb	227 kg
Lift capacity - extension deck extended	250 lb	113 kg	250 lb	113 kg
Max. platform drive height	14 ft 1 in	4.30 m	18 ft 2 in	5.55 m
Drive speed - stowed	2.5 mph	4.0 km/h	2.5 mph	4.0 km/h
Drive speed - raised	0.5 mph	0.8 km/h	0.5 mph	0.8 km/h
Gradeability - stowed ⁽²⁾	25%/14°		25%/14°	
Turning radius - inside/outside	0/4 ft 6 in	0/1.37 m	0/4 ft 6 in	0/1.37 m
Lifting speed - raise/lower	19/20 sec		26/20 sec	
Tilt sensor activation (front to back/side to side)	3°/1.5°		3°/1.5°	
Tires - solid non-marking	10×3 in	25.4×7.62 cm	10×3 in	25.4×7.62 cm

Power

Power	24V DC (2×12V 115Ah)	24V DC (2×12V 115Ah)
Hydraulic tank capacity (E-Drive)	1.5 gal	5.7L

Weight⁽³⁾ and Floor Loading⁽⁴⁾

Weight	1,985 lb	900 kg	2,600 lb	1,179 kg
Weight max. (adding all possible options)	2,064 lb	936 kg	2,680 lb	1,216 kg
Tire load max.	937 lb	425 kg	1257 lb	570 kg
Tire contact pressure	143 psi	988 kPa	164 psi	1,133 kPa
Occupied floor pressure	203 psf	9.73 kPa	254 psf	12.14 kPa

Sound and Vibration Levels

Sound Pressure level (ground workstation)	< 70 dBA		< 70 dBA	
Sound Pressure level (platform workstation)	< 70 dBA		< 70 dBA	
Vibrations	< 8 ft 2 in/s ²	< 2.5 m/s ²	< 8 ft 2 in/s ²	< 2.5 m/s ²

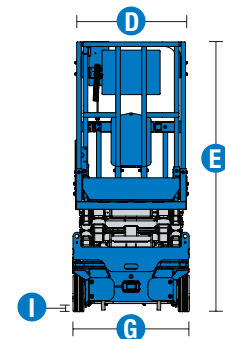
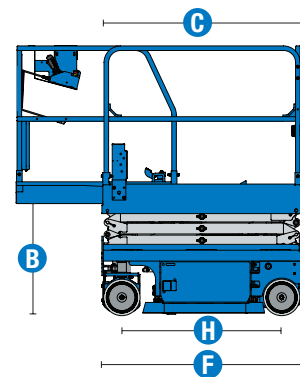
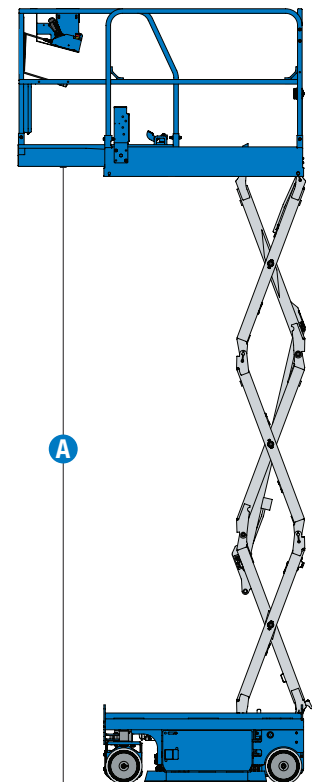

(1) The metric equivalent of working height adds 2 m to platform height. US adds 6 ft to platform height.

(2) Gradeability applies to driving on slopes and may vary depending on options and machine configurations. See operator's manual for details regarding slope ratings.

(3) Weight refers to standard configuration and may vary depending on options and/or country standards.

(4) Floor loading information is approximate and may vary depending on options and machine configurations. It should be used only with adequate safety factors.

Genie® GS™ -1432m & GS-1932m

SKU: Standard Model

- **GS1432M1AE0001:** GS-1432m, E-Drive

SKU: Standard Model

- **GS1932M1AE0001:** GS-1932m, E-Drive

* Build to Order

Option availability		S	S+	BtO
Power	Standard FLA flooded lead acid batteries	✓	✓	✓
	AGM Maintenance-free batteries		○	○
	Drive cut-out while charging		○	○
	Power Inverter		○	○
	Rear recessed charger receptacle	✓	✓	✓
Platform	Xtra Height (XH) Full Height Outdoor (GS-1932m)	✓	✓	✓
	Fixed rails, Half-height swing gate	✓	✓	✓
	Slide out extension deck	✓	✓	✓
	Air line to platform			○
	Automotive-style horn		○	○
	AC power to platform	✓	✓	✓
	Descent, tilt and motion alarm	✓	✓	✓
	Diamond plate platform deck	✓	✓	✓
	Dual LED flashing beacons	✓	✓	✓
	Electric horn	✓	✓	✓
	Lanyard attachment points	✓	✓	✓
	Platform control guard (PCON)	✓	✓	✓
	Platform load sense system	✓	✓	✓
	Proportional drive and lift	✓	✓	✓
	SmartLink dual zone control system	✓	✓	✓
Chassis	Lift Connect Telematics		○	○
	Lift Connect with Access Manager upgrade		○	○
	Lift Guard White Noise Alarm		○	○
	Lift Tools Spill Guard (E-Drive)		○	○
	Auxiliary platform lowering	✓	✓	✓
	Driveable at full height	✓	✓	✓
	Dual front wheel electric brakes	✓	✓	✓
	Dual front wheel sealed AC electric drive motors (E-Drive)	✓	✓	✓
	Electric brake release (E-Drive)	✓	✓	✓
	On board diagnostic system with battery charge indicator	✓	✓	✓
	Pothole protection	✓	✓	✓
	Rear fork pockets	✓	✓	✓
	Solid non-marking tires	✓	✓	✓
Tech Pro Link connector	✓	✓	✓	
Tie-down and lifting points	✓	✓	✓	

- S Standard
- S+ Standard +
- BtO Build to Order
- ✓ Standard Features
- Options



Compact Footprint



Lightweight



E-Drive



Genie Genuine Accessories⁽¹⁾

- Lift Tools Productivity Tools
- Lift Connect Telematics
- Tech Pro Link Handheld Device

(1) More accessories available from Genie Genuine Parts.

Product specifications are subject to change without notice or obligation. Photographs and/or drawings herein are for illustrative purposes only. Refer to the appropriate Operator's Manual for instructions on proper equipment use. Failure to follow instructions in the Operator's Manual may result in serious injury or death. The only warranty applicable to our equipment is the standard written warranty applicable to the particular product and sale and we make no other warranty, express or implied. Products and services listed may be trademarks, service marks or trade names of Terex Corporation and/or their subsidiaries in the USA and many other countries. Terex, Genie, Quality By Design, Xtra Capacity, Lift Power, Lift Guard, Lift Tools, Lift Connect and Tech Pro Link are registered trademarks of Terex Corporation or its subsidiaries.



QUOTATION

Monmouth Solutions, Inc
CAGE: 9DMG0
UEI: E474YENAVPB7

93 Butman Road
 Lowell, MA 01852

Voice: (978) 735-3855

Quoted To:
313 Anthony Center Drive, White Sulphur Springs, WV 24986

Customer ID	Good Thru	Payment Terms	Sales Rep
WV	10/31/2024	Net 30 Days	Anthony Farelli

Quantity	Item	Description	Unit Price	Amount
1	Genie GS-1932 or Genie GS-1932 Micro	Provide and deliver one (1) new Genie GS-1932 or Genie GS-1932 Micro.	\$17,799.00	\$17,799.00
			Subtotal	\$17,799.00
			Sales Tax	
			TOTAL	\$17,799.00

EXHIBIT A – Pricing Page
ARFQ DCR250000007
Genie GS – 1930, e-Drive, 110 V
GS1930E1CE0001 or Equal

Section	Description	Make and Model if bidding an or Equal	Unit of Measure	Quantity	Unit Cost	Extended Cost
3.1.1	Genie GS-1930 Scissor Lift for Anthony Correctional Center as noted in 3.1.1	Genie GS – 1930, e-Drive, 110 V GS1930E1CE0001 or Equal	EA	1	\$17,799.00	\$ 17,799.00
Overall Total Cost					\$	17,799.00

Vendor must complete and return this Pricing Page.

Any product or service not on the Agency provided Pricing Page will not be allowable. The State cannot accept an alternate Pricing Page, failure to use Exhibit A Pricing Page will lead to disqualification of vendor's bid. No future use of the Contract or any individual item is guaranteed or implied. A no bid entered in the Pricing Page will result in Vendor's bid being disqualified.

Vendor should type or electronically enter the information into the Pricing Page to prevent errors in the evaluation.

BIDDER /VENDOR INFORMATION:

Vendor Name:	Monmouth Solutions, Inc.
Address:	93 Butman Road
City, St. Zip:	Lowell, MA 01852
Phone No.:	(978) 735-3968
Email Address:	anthony@monmouthsolutions.com

Vendor Signature: AJF 9/25/2024

Date: 9/25/2024

REQUEST FOR QUOTATION

ARFQ 0608 DCR2500000020 Electric Slab Scissor Lifts for Anthony Correctional Center and Jail

SPECIFICATIONS

1. **PURPOSE AND SCOPE:** The West Virginia Department of Homeland Security - Division of Administrative Services (DAS) is soliciting bids on behalf of the West Virginia Division of Corrections and Rehabilitation (DCR) for Anthony Correctional Center and Jail to establish a contract for one time purchase of one Electric Slab Scissor Lift. The facility is located at 313 Anthony Center Drive, White Sulphur Springs, WV 24986.
2. **DEFINITIONS:** Definitions can be found in Section 2 of the General Terms and Conditions. The terms listed below shall have the meanings assigned to them as follows:
 - 2.1 **“Business Hours”** means Monday – Friday 8:00 AM to 5:00 PM EST excluding weekends and Federal and State holidays, which are as follows:
 - New Year’s Day (January 1)
 - Martin Luther King Day (Third Monday in January)
 - President’s Day (Third Monday in February)
 - Memorial Day (Last Monday in May)
 - Juneteenth (June 19)
 - West Virginia Day (June 20)
 - Independence Day (July 4)
 - Labor Day (First Monday in September)
 - Columbus Day (Second Monday in October)
 - Veterans Day (November 11)
 - Thanksgiving (Fourth Thursday in November)
 - Day After Thanksgiving (Fourth Friday in November)
 - Christmas Day (December 25)
 - 2.2 **“Contract Items”** means the list of items identified in Section 3.1 below and on the Pricing Page.
 - 2.3 **“Pricing Page”** means the schedule of prices, estimated order quantity, and totals contained in wvOASIS or attached hereto as Exhibit A and used to evaluate the Solicitation responses.
 - 2.4 **“Solicitation”** means the official notice of an opportunity to supply the State with goods or services that is published by the West Virginia Division of Administrative Services.

REQUEST FOR QUOTATION

ARFQ 0608 DCR2500000020 Electric Slab Scissor Lifts for Anthony Correctional Center and Jail

3. GENERAL REQUIREMENTS:

3.1 Contract Items and Mandatory Requirements: Vendor shall provide Agency with the Contract Item listed below on a one-time basis. Contract Items must meet or exceed the mandatory requirements as shown below.

3.1.1 Contract Item 1: Genie GS – 1930, e-Drive, 110 V GS1930E1CE0001 or Equal

3.1.1.1 Vendor must provide a quantity of one (1) Genie GS – 1930, E-Drive, 110 V GS1930E1CE0001 New Lift or Equal with the following features:

- 3.1.1.1.1** Must have a working height maximum of 25 feet 3 inches in an indoor space.
- 3.1.1.1.2** Must have a working height maximum of 20 feet 8 inches in an outdoor space.
- 3.1.1.1.3** Must have a machine height at folding rails stowed of 7 feet 1 inches with a machine height at rails lowered stowed with 5 feet 11 inches. Must have a stowed machine length at 6 feet and a stowed extended machine length at 8 feet 11 inches.
- 3.1.1.1.4** Must have a machine minimum width of 2 feet 6.2 inches with a machine wheelbase minimum of 4 feet 4 inches.
- 3.1.1.1.5** Must have a minimum ground clearance for machine center with pothole guards retracted of 3.2 inches. Must have a minimum ground clearance for the machine with pothole guards deployed of 0.9 inches.
- 3.1.1.1.6** Must have a platform with Folding rails, Half-height swing gate, Slide out extension deck, power to platform – no RCBO, AC power to platform, descent – tilt and motion alarm, diamond plat platform deck, dual led flashing beacons, electric horn, lanyard attachment points, platform control guard (PCON), platform load sense system, proportional drive and lift, and SmartLink dual zone control system. Must have a platform height max indoor of 19 feet 3 inches, platform height max outdoor of 14 feet 8 inches, platform height stowed of 3 feet 5 inches, platform length outside 5 feet 5 inches, platform length outside extended 8 feet 5 inches, slide-out platform extension deck length 2 feet 11.8 inches, platform width outside guardrail height 3 feet 7 inches, and platform width outside toeboard height 6 inches.
- 3.1.1.1.7** A minimum of the standard power for Genie GS-1930

REQUEST FOR QUOTATION

ARFQ 0608 DCR2500000020 Electric Slab Scissor Lifts for Anthony Correctional Center and Jail

- Models as standard FLA flooded lead acid batteries, 24V DC (4x6V 210 Ah), and rear recessed charger receptacle with a hydraulic tank capacity (E-Drive) of 1 gallon.
- 3.1.1.1.8** A minimum chassis with auxiliary platform lowering, drivable at full height, dual front wheel sealed AC electric drive motors (E-Drive), lift tools spill guard (E-Drive), dual wheel multi-disc brakes, electric brake release (E-Drive), on board diagnostic system with battery charge indicator, pothole protection, side and rear fork pockets, solid non-marking tires, tech pro link connector, and tie-down and lifting points.
- 3.1.1.1.9** Must have a minimum of maximum platform occupancy in and out of 2/1, lift capacity of 500 pounds, lift capacity with extension deck extended of 250 pounds, maximum platform drive height of 19 feet and 3 inches, drive speed stowed at 2.5 mph, drive speed raised at 0.5 mph, gradeability stowed at 25%, turning radius inside and outside of 0/5 feet 1 inch, lifting speed raise 26 seconds, lifting speed lower 22 seconds, tilt sensor activation front to back of 3 degrees and 1.5 degrees for tilt sensor activation side to side, and tires solid non-marking for 12 x 4.5 inches.
- 3.1.1.1.10** Must have a minimum weight of 3,209 pounds, weight maximum of 3,354 pounds with adding all possible options, tire load maximum 1,483 pounds, tire contact pressure 165 psi, occupied floor pressure 287 psf.
- 3.1.1.1.11** Must have a minimum of sound pressure level with ground workstation < 70 dBA, sound pressure level with platform workstation < 70 dBA, and vibrations of <8 feet 2 inches/s²
- 3.1.2 Workmanship:** Lift shall be free from defects that may impair operation, safety, emissions, and serviceability, or detract from appearance.

REQUEST FOR QUOTATION

ARFQ 0608 DCR250000020 Electric Slab Scissor Lifts for Anthony Correctional Center and Jail

3.1.3 Alternative 'or Equal' Submission

3.1.3.1 A Vendor submitting an alternate brand item must provide alternate brand information and documentation with their bid response, i.e., brochures, pamphlets, product specs, MSDS sheets, etc. Failure to submit substitute brand information and documentation will result in the bid being disqualified.

4. CONTRACT AWARD:

4.1 Contract Award: The Contract is intended to provide the Agency with a purchase price on all Contract Items. The Contract shall be awarded to the Vendor that provides the Contract Item meeting the required specifications for the lowest overall total cost as shown on the Pricing Page.

4.2 Pricing Page: Vendor must complete the Pricing Page by providing unit cost for each contract service. A Vendor must complete the Pricing Page in their entirety as failure to do so will result in Vendor's bids being disqualified. A no bid entered on the Pricing Page will result in Vendor's bid being disqualified.

Any product or service not on the Agency provided Pricing Page will not be allowable. The state cannot accept alternate pricing pages, failure to use Exhibit A - Pricing Page could lead to disqualification of Vendor's bid.

The Pricing Page contains a list of the Contract Items and estimated purchase volume. The estimated purchase volume for each item represents the approximate volume of anticipated purchases only. No future use of the Contract or any individual item is guaranteed or implied.

Vendors shall electronically enter the information into the Pricing Page through wvOASIS, if available, or as an electronic document. In most cases, Vendor can request an electronic copy of the Pricing Page for bid purposes by sending an email request to the following email address: erin.a.webb@wv.gov

Confidentiality Policies and Information Security Accountability: Vendor agrees to adhere to the Confidentiality Policies and Information Security Accountability Requirements Which can be found at: <https://www.state.wv.us/admin/purchase/privacy/> At the Agencies discretion, the Agency can require the Vendor and its employees to execute the Confidentiality Agreement.

REQUEST FOR QUOTATION

ARFQ 0608 DCR2500000020
Electric Slab Scissor Lifts for
Anthony Correctional Center and Jail

5. PAYMENT:

5.1 Payment: Vendor shall accept payment in accordance with the payment procedures of the State of West Virginia.

6. DELIVERY AND RETURN:

6.1 Shipment and Delivery: Vendor shall ship the Contract Items immediately after being awarded this Contract and receiving a purchase order or notice to proceed. Vendor shall deliver the Contract Item within 10 working days after receiving a purchase order or notice to proceed. Contract Item must be delivered to the Agency address below:

Anthony Correctional Center and Jail
313 Anthony Center Drive
White Sulphur Springs, WV 24986

6.2 Late Delivery: The Agency placing the order under this Contract must be notified in writing if the shipment of the Contract Item will be delayed for any reason. Any delay in delivery that could cause harm to an Agency will be ground for cancellation of the Contract, and/or obtaining the Contract Item from a third party.

6.3 Delivery Payment/Risk of Loss: Vendor shall deliver the Contract Item F.O.B destination to the Agency's location

6.4 Return of Unacceptable Items: If Agency deems the Contract Item to be unacceptable, the Contract Item shall be returned to Vendor at Vendor's expense and with no restocking charge. The Vendor shall either arrange for the return within five (5) days of being notified that item is unacceptable or permit the Agency to arrange for the return and reimburse Agency for delivery expenses. If the original packaging cannot be utilized for the return, Vendor will supply the Agency with appropriate return packaging upon request. All returns of unacceptable items shall be F.O.B. Agency's location. The returned product shall either be replaced, or the Agency shall receive full credit or refund for the purchase price, at Agency's discretion.

REQUEST FOR QUOTATION

ARFQ 0608 DCR250000020
Electric Slab Scissor Lifts for
Anthony Correctional Center and Jail

6.5 Return Due to Agency Error: Items ordered in error by the Agency will be returned for credit within 30 days of receipt, F.O.B. Vendor's location. Vendor shall not charge a restocking fee if returned products are in a resalable condition. Items shall be deemed to be in a resalable condition if they are unused and in the original packaging. Any restocking fee for an item not in a resalable condition shall be the lower of the Vendor's customary restocking fee or 5% of the total invoiced value of the returned item.

7 VENDOR DEFAULT:

7.1 The following shall be considered a Vendor default under this Contract.

- 7.1.1** Failure to provide Contract Item in accordance with the requirements contained herein.
- 7.1.2** Failure to comply with other specifications and requirements contained herein.
- 7.1.3** Failure to comply with any laws, rules, and ordinances applicable to the Contract Services provided under this Contract.
- 7.1.4** Failure to remedy deficient performance upon request.

7.2 The following remedies shall be available to the Agency upon default.

- 7.2.1** Immediate cancellation of the Contract.
- 7.2.2** Immediate cancellation of one or more release orders issued under this Contract.
- 7.2.3** Any other remedies available in law or equity.

REQUEST FOR QUOTATION

ARFQ 0608 DCR2500000020
Electric Slab Scissor Lifts for
Anthony Correctional Center and Jail

8 MISCELLANEOUS:

8.1 Contract Manager: During its performance of this Contract, Vendor must designate and maintain a primary contract manager responsible for overseeing Vendor's responsibilities under this Contract. The Contract manager must be available during normal business hours to address any customer service or other issues related to this Contract. Vendor should list its Contract manager and his or her contact information below.

Contract Manager:	Anthony Farelli
Telephone Number:	(978) 735-3968
Fax Number:	N/A
Email Address:	anthony@monmouthsolutions.com

INSTRUCTIONS TO VENDORS SUBMITTING BIDS

1. REVIEW DOCUMENTS THOROUGHLY: The attached documents contain a solicitation for bids. Please read these instructions and all documents attached in their entirety. These instructions provide critical information about requirements that if overlooked could lead to disqualification of a Vendor's bid. All bids must be submitted in accordance with the provisions contained in these instructions and the Solicitation. Failure to do so may result in disqualification of Vendor's bid.

2. MANDATORY TERMS: The Solicitation may contain mandatory provisions identified by the use of the words "must," "will," and "shall." Failure to comply with a mandatory term in the Solicitation will result in bid disqualification.

2A. PREBID MEETING: The item identified below shall apply to this Solicitation.

A pre-bid meeting will not be held prior to bid opening.

A Non-Mandatory PRE-BID meeting will be held at the following place and time:

A MANDATORY PRE-BID meeting will be held at the following place and time:

All Vendors submitting a bid must attend the mandatory pre-bid meeting. Failure to attend the mandatory pre-bid meeting shall result in disqualification of the Vendor's bid. No one individual is permitted to represent more than one vendor at the pre-bid meeting. Any individual that does attempt to represent two or more vendors will be required to select one vendor to which the individual's attendance will be attributed. The vendors not selected will be deemed to have not attended the pre-bid meeting unless another individual attended on their behalf. The required attribution of attendance to a single vendor should be addressed during the pre-bid but may occur at any time deemed appropriate by the Agency.

An attendance sheet provided at the pre-bid meeting shall serve as the official document verifying attendance. Any person attending the pre-bid meeting on behalf of a Vendor must list on the attendance sheet his or her name and the name of the Vendor he or she is representing.

Additionally, the person attending the pre-bid meeting should include the Vendor's E-Mail address, phone number, and Fax number on the attendance sheet. It is the Vendor's responsibility to locate the attendance sheet and provide the required information. Failure to complete the attendance sheet as required may result in disqualification of Vendor's bid.

All Vendors should arrive prior to the starting time for the pre-bid. Vendors who arrive after the starting time but prior to the end of the Prebid will be permitted to sign in but are charged with knowing all matters discussed at the Prebid.

Questions submitted at least five business days prior to a scheduled pre-bid will be discussed at the pre-bid meeting if possible. Any discussions or answers to questions at the pre-bid meeting are preliminary in nature and are non-binding. Official and binding answers to questions will be published in a written addendum to the Solicitation prior to bid opening.

3. VENDOR QUESTION DEADLINE: Vendors may submit questions relating to this Solicitation to the Agency Contact. Questions must be submitted in writing. All questions must be submitted on or before the date listed below and to the address listed below to be considered. A written response will be published in a Solicitation addendum if a response is possible and appropriate. Non-written discussions, conversations, or questions and answers regarding this Solicitation are preliminary in nature and are nonbinding.

Submitted emails should have the solicitation number in the subject line.

Question Submission Deadline: **Wednesday September 18th, 2024**

Submit Questions to: **A. Erin Webb**

Email: erin.a.webb@wv.gov

4. BID SUBMISSION: All bids must be submitted electronically through wvOASIS or signed and delivered by the Vendor to the Agency on or before the date and time of the bid opening. Any bid received by the Agency staff is considered to be in the possession of the Agency and will not be returned for any reason.

4A. BID SUBMISSION

A bid that is not submitted electronically through wvOASIS should contain the information listed below on the face of the envelope or the bid may be rejected by the Agency.

SEALED BID: **yes**

BUYER: **A. Erin Webb**

SOLICITATION NUMBER: **ARFQ 0608 DCR2500000020**

BID OPENING DATE: **Wednesday 9-25-24**

BID OPENING TIME: **11:00 AM**

FAX NUMBER: **3045581426**

5. ADDENDUM ACKNOWLEDGEMENT: Changes or revisions to this Solicitation will be made by an official addendum issued by the Agency. Vendors should acknowledge receipt of all addenda issued with this Solicitation by completing an Addendum Acknowledgment Form, a copy of which is included herewith. Failure to acknowledge addenda may result in bid disqualification. The addendum acknowledgement should be submitted with the bid to expedite document processing.

6. BID FORMATTING: Vendor should type or electronically enter the information onto its bid to prevent errors in the evaluation. Failure to type or electronically enter the information may result in bid disqualification.

7. ALTERNATE MODEL OR BRAND: Unless the box below is checked, any model, brand, or specification listed in this Solicitation establishes the acceptable level of quality only and is not intended to reflect a preference for, or in any way favor, a particular brand or vendor. Vendors may bid alternates to a listed model or brand provided that the alternate is at least equal to the model or brand and complies with the required specifications. The equality of any alternate being bid shall be determined by the State at its sole discretion. Any Vendor bidding an alternate model or brand should clearly identify the alternate items in its bid and should include manufacturer's specifications, industry literature, and/or any other relevant documentation demonstrating the equality of the alternate items. Failure to provide information for alternate items may be grounds for rejection of a Vendor's bid.

This Solicitation is based upon a standardized commodity. Vendors are expected to bid the standardized commodity identified. Failure to bid the standardized commodity will result in your firm's bid being rejected.

8. EXCEPTIONS AND CLARIFICATIONS: The Solicitation contains the specifications that shall form the basis of a contractual agreement. Vendor shall clearly mark any exceptions, clarifications, or other proposed modifications in its bid. Exceptions to, clarifications of, or modifications of a requirement or term and condition of the Solicitation may result in bid disqualification.

9. REGISTRATION: Prior to Contract award, the apparent successful Vendor must be properly registered with the Agency and must have paid the \$125 fee, if applicable.

10. UNIT PRICE: Unit prices shall prevail in cases of a discrepancy in the Vendor's bid.

11. ELECTRONIC FILE ACCESS RESTRICTIONS: Vendor must ensure that its submission in wvOASIS can be accessed and viewed by the Agency staff immediately upon bid opening. The Agency will consider any file that cannot be immediately access and viewed at the time of the bid opening (such as, encrypted files, password protected files, or incompatible files) to be blank or incomplete as context requires, and therefore unacceptable. A vendor will not be permitted to unencrypt files, remove password protections, or resubmit documents after bid opening to make a file viewable if those documents are required with the bid. A Vendor may be required to provide document passwords or removed access restrictions to allow the Agency to print or electronically save documents provided that those documents are viewable by the Agency prior to obtaining the password or removing the access restriction.

12. NON-RESPONSIBLE: The Director of Administrative Services reserves the right to reject the bid of any vendor as non-responsible, when the Director determines that the vendor submitting the bid does not have the capability to fully perform or lacks the integrity and reliability to assure good-faith performance.

13. ACCEPTANCE/REJECTION: The State may accept or reject any bid in whole, or in part.

14. YOUR SUBMISSION IS A PUBLIC DOCUMENT: Vendor's entire response to the Solicitation and the resulting Contract are public documents. As public documents, they will be disclosed to the public following the bid/proposal opening or award of the contract, Freedom of Information Act in West Virginia Code §§ 29B-1-1 et seq.

DO NOT SUBMIT MATERIAL YOU CONSIDER TO BE CONFIDENTIAL, A TRADE SECRET, OR OTHERWISE NOT SUBJECT TO PUBLIC DISCLOSURE.

Submission of any bid, proposal, or other document to the Agency constitutes your explicit consent to the subsequent public disclosure of the bid, proposal, or document. The Agency will disclose any document labeled "confidential," "proprietary," "trade secret," "private," or labeled with any other claim against public disclosure of the documents, to include any "trade secrets" as defined by West Virginia Code § 47-22-1 et seq. All submissions are subject to public disclosure without notice.

GENERAL TERMS AND CONDITIONS:

1. **CONTRACTUAL AGREEMENT:** Issuance of an Award Document signed by the Agency and approved as to form by the Attorney General's office, if required, constitutes acceptance of this Contract made by and between the State of West Virginia and the Vendor. Vendor's signature on its bid signifies Vendor's agreement to be bound by and accept the terms and conditions contained in this Contract.
2. **DEFINITIONS:** As used in this Solicitation/Contract, the following terms shall have the meanings attributed to them below. Additional definitions may be found in the specifications included with this Solicitation/Contract.
 - 2.1. **"Agency" or "Agencies"** means the agency, board, commission, or other entity of the State of West Virginia that is identified on the first page of the Solicitation or any other public entity seeking to procure goods or services under this Contract.
 - 2.2. **"Bid" or "Proposal"** means the vendors submitted response to this solicitation.
 - 2.3. **"Contract"** means the binding agreement that is entered into between the State and the Vendor to provide the goods or services requested in the Solicitation.
 - 2.4. **"Director"** means the Director of the West Virginia Division of Administrative Services.
 - 2.5. **"Award Document"** means the document signed by the Agency that identifies the Vendor as the contract holder.
 - 2.6. **"Solicitation"** means the official notice of an opportunity to supply the State with goods or services.
 - 2.7. **"State"** means the State of West Virginia and/or any of its agencies, commissions, boards, etc. as context requires.
 - 2.8. **"Vendor" or "Vendors"** means any entity submitting a bid in response to the Solicitation, the entity that has been selected as the lowest responsible bidder, or the entity that has been awarded the Contract as context requires.

3. **CONTRACT TERM; RENEWAL; EXTENSION:** The term of this Contract shall be determined in accordance with the category that has been identified as applicable to this Contract below:

Term Contract

Initial Contract Term: This Contract becomes effective on the date indicated on the awarded contract and extends for a period of _____ year(s).

Renewal Term: This Contract may be renewed upon the mutual written consent of the Agency, and the Vendor. Any request for renewal should be delivered to the Agency thirty (30) days prior to the expiration date of the initial contract term or appropriate renewal term. A Contract renewal shall be in accordance with the terms and conditions of the original contract. Unless otherwise specified below, renewal of this Contract is limited to _____ successive one (1) year periods or multiple renewal periods of less than one year, provided that the multiple renewal periods do not exceed the total number of months available in all renewal years combined. Automatic renewal of this Contract is prohibited.

Alternate Renewal Term – This contract may be renewed for _____ successive _____ year periods or shorter periods provided that they do not exceed the total number of months contained in all available renewals. Automatic renewal of this Contract is prohibited. Renewals must be approved by the Vendor and Agency.

Delivery Order Limitations: In the event that this contract permits delivery orders, a delivery order may only be issued during the time this Contract is in effect. Any delivery order issued within one year of the expiration of this Contract shall be effective for one year from the date the delivery order is issued. No delivery order may be extended beyond one year after this Contract has expired.

Fixed Period Contract: This Contract becomes effective upon Vendor's receipt of the notice to proceed and must be completed within _____ days.

Fixed Period Contract with Renewals: This Contract becomes effective upon Vendor's receipt of the notice to proceed and part of the Contract more fully described in the attached specifications must be completed within _____ days. Upon completion of the work covered by the preceding sentence, the vendor agrees that maintenance, monitoring, or warranty services will be provided for _____ year(s) thereafter.

One Time Purchase: The term of this Contract shall run from the issuance of the Award Document until all of the goods contracted for have been delivered, but in no event will this Contract extend for more than one fiscal year.

Other: See attached.

4. **NOTICE TO PROCEED:** Vendor shall begin performance of this Contract immediately upon receiving notice to proceed unless otherwise instructed by the Agency. Unless otherwise specified, the fully executed Award Document will be considered notice to proceed.

5. **QUANTITIES:** The quantities required under this Contract shall be determined in accordance with the category that has been identified as applicable to this Contract below.

Open End Contract: Quantities listed in this Solicitation are approximations only, based on estimates supplied by the Agency. It is understood and agreed that the Contract shall cover the quantities actually ordered for delivery during the term of the Contract, whether more or less than the quantities shown.

Service: The scope of the service to be provided will be more clearly defined in the specifications included herewith.

Combined Service and Goods: The scope of the service and deliverable goods to be provided will be more clearly defined in the specifications included herewith.

One Time Purchase: This Contract is for the purchase of a set quantity of goods that are identified in the specifications included herewith. Once those items have been delivered, no additional goods may be procured under this Contract without an appropriate change order approved by the Vendor, Agency, and Attorney General's office.

6. **REQUIRED DOCUMENTS:** All of the items checked below must be provided to the Agency by the Vendor as specified below.

PERFORMANCE BOND: The apparent successful Vendor shall provide a performance bond in the amount of 100% of the contract value. The performance bond must be received by the Agency prior to Contract award.

LABOR/MATERIAL PAYMENT BOND: The apparent successful Vendor shall provide a labor/material payment bond in the amount of 100% of the Contract value. The labor/material payment bond must be received by the Agency prior to Contract award.

MAINTENANCE BOND: The apparent successful Vendor shall provide a two (2) year maintenance bond covering the roofing system. The maintenance bond must be issued and delivered to the Agency prior to Contract award.

LICENSE(S) / CERTIFICATIONS / PERMITS: In addition to anything required under the Section of the General Terms and Conditions entitled Licensing, the apparent successful Vendor shall furnish proof of the following licenses, certifications, and/or permits upon request and in a form acceptable to the State. The request may be prior to or after the contract award at the State's sole discretion.

The apparent successful Vendor shall also furnish proof of any additional licenses or certifications contained in the specifications regardless of whether or not that requirement is listed above.

7. INSURANCE: The apparent successful Vendor shall furnish proof of the insurance identified by a checkmark below and must include the State as an additional insured on each policy prior to Contract award. The insurance coverage identified below must be maintained throughout the life of this contract. Thirty (30) days prior to the expiration of the insurance policies Vendor shall provide the Agency with proof that the insurance mandated herein has been continued. Vendor must also provide Agency with immediate notice of any changes in its insurance policies, including but not limited to, policy cancelation, policy reduction, or change in insurers. The apparent successful Vendor shall also furnish proof of any additional insurance requirements contained in the specifications prior to Contract award regardless of whether or not that insurance requirement is listed in this section.

Vendor must maintain:

- Commercial General Liability Insurance** in at least an amount of: \$1,000,000 limits of coverage per occurrence.
- Automobile Liability Insurance** in at least an amount of: \$1,000,000 or waived if being delivered via a 3rd party delivery service per occurrence.
- Professional/Malpractice/Errors and Omission Insurance** in at least an amount of: _____ per occurrence. Notwithstanding the forgoing, Vendor's are not required to list the State as an additional insured for this type of policy.
- Commercial Crime and Third-Party Fidelity Insurance** in an amount of: _____ per occurrence.
- Cyber Liability Insurance** in the amount of: _____ per occurrence.
- Builders Risk Insurance** in an amount equal to 100% of the amount of the Contract.
- Pollution Insurance** in the amount of: _____ per occurrence.
- Aircraft Liability** in the amount of: _____ per occurrence.

8. WORKERS' COMPENSATION INSURANCE: The apparent successful Vendor shall comply with laws relating to workers' compensation, shall maintain workers' compensation insurance when required, and shall furnish proof of workers' compensation insurance upon request.

9. **LIQUIDATED DAMAGES:** This clause shall in no way be considered exclusive and shall not limit the State or Agency's right to pursue any other available remedy. Vendor shall pay liquidated damages in the amount specified below or as described in the specifications:

_____ for _____

Liquidated Damages Contained in the Specifications

10. **ACCEPTANCE:** Vendor's signature on its bid, or on the certification and signature page, constitutes an offer to the State that cannot be unilaterally withdrawn, signifies that the product or service proposed by vendor meets the mandatory requirements contained in the Solicitation for that product or service, unless otherwise indicated, and signifies acceptance of the terms and conditions contained in the Solicitation unless otherwise indicated.

11. **PRICING:** The pricing set forth herein is firm for the life of the Contract, unless specified elsewhere within this Solicitation/Contract by the State. A Vendor's inclusion of price adjustment provisions in its bid, without an express authorization from the State in the Solicitation to do so, may result in bid disqualification. Notwithstanding the foregoing, Vendor must extend any publicly advertised sale price to the State and invoice at the lower of the contract price or the publicly advertised sale price.

12. **PAYMENT IN ARREARS:** Payment in advance is prohibited under this Contract. Payment may only be made after the delivery and acceptance of goods or services. The Vendor shall submit invoices, in arrears.

13. **PAYMENT METHODS:** Vendor must accept payment by electronic funds transfer or P-Card. (The State of West Virginia's Purchasing Card program, administered under contract by a banking institution, processes payment for goods and services through state designated credit cards.)

14. **ADDITIONAL FEES:** Vendor is not permitted to charge additional fees or assess additional charges that were not either expressly provided for in the solicitation published by the State of West Virginia or included in the unit price or lump sum bid amount that Vendor is required by the solicitation to provide. Including such fees or charges as notes to the solicitation may result in rejection of vendor's bid. Requesting such fees or charges be paid after the contract has been awarded may result in cancellation of the contract.

15. **TAXES:** The Vendor shall pay any applicable sales, use, personal property or any other taxes arising out of this Contract and the transactions contemplated thereby. The State of West Virginia is exempt from federal and state taxes and will not pay or reimburse such taxes.

16. **FUNDING:** This Contract shall continue for the term stated herein, contingent upon funds being appropriated by the Legislature or otherwise being made available. In the event funds are not appropriated or otherwise made available, this Contract becomes void and of no effect beginning on July 1 of the fiscal year for which funding has not been appropriated or otherwise made available.

17. CANCELLATION: The State reserves the right to cancel this Contract immediately upon written notice to the vendor if the materials or workmanship supplied do not conform to the specifications contained in the Contract. The Agency may also cancel any purchase or Contract upon 30 days written notice to the Vendor.

18. TIME: Time is of the essence with regard to all matters of time and performance in this Contract.

19. APPLICABLE LAW: This Contract is governed by and interpreted under West Virginia law without giving effect to its choice of law principles. Any information provided in specification manuals, or any other source, verbal or written, which contradicts or violates the West Virginia Constitution, West Virginia Code or West Virginia Code of State Rules is void and of no effect.

19A. VENUE: All legal actions for damage brought by Vendor against the State shall be brought in the West Virginia Claims Commission. Other causes of action must be brought in the West Virginia court authorized by statute to exercise jurisdiction over it.

20. COMPLIANCE WITH LAWS: Vendor shall comply with all applicable federal, state, and local laws, regulations, and ordinances. By submitting a bid, Vendor acknowledges that it has reviewed, understands, and will comply with all applicable laws, regulations, and ordinances. Vendor shall notify all subcontractors providing commodities or services related to this Contract that as subcontractors, they too are required to comply with all applicable laws, regulations, and ordinances.

21. ARBITRATION: Any references made to arbitration contained in this Contract, Vendor's bid, or in any American Institute of Architects documents pertaining to this Contract are hereby deleted, void, and of no effect.

22. MODIFICATIONS: This writing is the parties' final expression of intent. Notwithstanding anything contained in this Contract, to the contrary, no modification of this Contract shall be binding without mutual written consent of the Agency and the Vendor.

23. WAIVER: The failure of either party to insist upon a strict performance of any of the terms or provision of this Contract, or to exercise any option, right, or remedy herein contained, shall not be construed as a waiver or a relinquishment for the future of such term, provision, option, right, or remedy, but the same shall continue in full force and effect. Any waiver must be expressly stated in writing and signed by the waiving party.

24. SUBSEQUENT FORMS: The terms and conditions contained in this Contract shall supersede any and all subsequent terms and conditions which may appear on any form documents submitted by Vendor to the Agency such as price lists, order forms, invoices, sales agreements, or maintenance agreements, and includes internet websites or other electronic documents. Acceptance or use of Vendor's forms does not constitute acceptance of the terms and conditions contained thereon.

25. ASSIGNMENT: Neither this Contract nor any monies due, or to become due hereunder, may be assigned by the Vendor without the express written consent of the Agency and any other government agency or office that may be required to approve such assignments.

26. WARRANTY: The Vendor expressly warrants that the goods and/or services covered by this Contract will: (a) conform to the specifications, drawings, samples, or other description furnished or specified by the Agency; (b) be merchantable and fit for the purpose intended; and (c) be free from defects in material and workmanship.

27. STATE EMPLOYEES: State employees are not permitted to utilize this Contract for personal use and the Vendor is prohibited from permitting or facilitating the same.

28. PRIVACY, SECURITY, AND CONFIDENTIALITY: The Vendor agrees that it will not disclose to anyone, directly or indirectly, any such personally identifiable information or other confidential information gained from the Agency, unless the individual who is the subject of the information consents to the disclosure in writing or the disclosure is made pursuant to the Agency's policies, procedures, and rules. Vendor further agrees to comply with the Confidentiality Policies and Information Security Accountability Requirements, set forth in:
<http://www.state.wv.us/admin/purchase/privacy/default.html>

28A. CONFIDENTIALITY POLICIES AND INFORMATION SECURITY

ACCOUNTABILITY: The Vendor agrees to adhere to the Confidentiality Policies and Information Accountability Requirements set forth in the link below. At the Agencies sole discretion, the Agency can require the Vendor and its employees to execute the confidentiality agreement.
<http://www.state.wv.us/admin/purchase/privacy/default.html>

29. YOUR SUBMISSION IS A PUBLIC DOCUMENT: Vendor's entire response to the Solicitation and the resulting Contract are public documents. As public documents, they will be disclosed to the public following the bid/proposal opening or award of the contract, as required by the competitive bidding laws of the State of West Virginia and the Freedom of Information Act West Virginia Code §§ 29B-1-1 et seq.

DO NOT SUBMIT MATERIAL YOU CONSIDER TO BE CONFIDENTIAL, A TRADE SECRET, OR OTHERWISE NOT SUBJECT TO PUBLIC DISCLOSURE.

Submission of any bid, proposal, or other document to the Agency constitutes your explicit consent to the subsequent public disclosure of the bid, proposal, or document. The Agency will disclose any document labeled "confidential," "proprietary," "trade secret," "private," or labeled with any other claim against public disclosure of the documents, to include any "trade secrets" as defined by West Virginia Code § 47-22-1 et seq. All submissions are subject to public disclosure without notice.

30. LICENSING: In accordance with applicable law, Vendor must be licensed and in good standing in accordance with any and all state and local laws and requirements by any state or local agency of West Virginia, including, but not limited to, the West Virginia Secretary of State's Office, the West Virginia Tax Department, West Virginia Insurance Commission, or any other state agency or political subdivision. Obligations related to political subdivisions may include, but are not limited to, business licensing, business and occupation taxes, inspection compliance, permitting, etc. Upon request, the Vendor must provide all necessary releases to obtain information to enable the Agency to verify that the Vendor is licensed and in good standing with the above entities. Vendor shall notify all subcontractors providing commodities or services related to this Contract that as subcontractors, they too are required to be licensed, in good standing, and up to date on all state and local obligations as described in this section.

31. ANTITRUST: In submitting a bid to, signing a contract with, or accepting an Award Document from any agency of the State of West Virginia, the Vendor agrees to convey, sell, assign, or transfer to the State of West Virginia all rights, title, and interest in and to all causes of action it may now or hereafter acquire under the antitrust laws of the United States and the State of West Virginia for price fixing and/or unreasonable restraints of trade relating to the particular commodities or services purchased or acquired by the State of West Virginia. Such assignment shall be made and become effective at the time the purchasing agency tenders the initial payment to Vendor.

32. VENDOR CERTIFICATIONS: By signing its bid or entering into this Contract, Vendor certifies (1) that its bid or offer was made without prior understanding, agreement, or connection with any corporation, firm, limited liability company, partnership, person or entity submitting a bid or offer for the same material, supplies, equipment or services; (2) that its bid or offer is in all respects fair and without collusion or fraud; (3) that this Contract is accepted or entered into without any prior understanding, agreement, or connection to any other entity that could be considered a violation of law; and (4) that it has reviewed this Solicitation in its entirety; understands the requirements, terms and conditions, and other information contained herein. Vendor's signature on its bid or offer also affirms that neither it nor its representatives have any interest, nor shall acquire any interest, direct or indirect, which would compromise the performance of its services hereunder. Any such interests shall be promptly presented in detail to the Agency. The individual signing this bid or offer on behalf of Vendor certifies that he or she is authorized by the Vendor to execute this bid or offer, or any documents related thereto on

Vendor's behalf: that he or she is authorized to bind the Vendor in a contractual relationship; and that, to the best of his or her knowledge, the Vendor has properly registered with any State agency that may require registration.

33. VENDOR RELATIONSHIP: The relationship of the Vendor to the State shall be that of an independent contractor and no principal-agent relationship or employer-employee relationship is contemplated or created by this Contract. The Vendor as an independent contractor is solely liable for the acts and omissions of its employees and agents. Vendor shall be responsible for selecting, supervising, and compensating any and all individuals employed pursuant to the terms of this Solicitation and resulting contract. Neither the Vendor, nor any employees or subcontractors of the Vendor, shall be deemed to be employees of the State for any purpose whatsoever. Vendor shall be exclusively responsible for payment of employees and contractors for all wages and salaries, taxes, withholding payments, penalties, fees, fringe benefits, professional liability insurance premiums, contributions to insurance and pension, or other deferred compensation plans, including but not limited to, Workers' Compensation and Social Security obligations, licensing fees, etc. and the filing of all necessary documents, forms, and returns pertinent to all of the foregoing. Vendor shall hold harmless the State and shall provide the State and Agency with a defense against any and all claims including, but not limited to, the foregoing payments, withholdings, contributions, taxes, Social Security taxes, and employer income tax returns.

34. INDEMNIFICATION: The Vendor agrees to indemnify, defend, and hold harmless the State and the Agency, their officers, and employees from and against: (1) Any claims or losses for services rendered by any subcontractor, person, or firm performing or supplying services, materials, or supplies in connection with the performance of the Contract; (2) Any claims or losses resulting to any person or entity injured or damaged by the Vendor, its officers, employees, or subcontractors by the publication, translation, reproduction, delivery, performance, use, or disposition of any data used under the Contract in a manner not authorized by the Contract, or by Federal or State statutes or regulations; and (3) Any failure of the Vendor, its officers, employees, or subcontractors to observe State and Federal laws including, but not limited to, labor and wage and hour laws.

35. NO DEBT CERTIFICATION: In accordance with West Virginia Code, the State is prohibited from awarding a contract to any bidder that owes a debt to the State or a Political subdivision of the State. By submitting a bid, or entering into a contract with the State, Vendor is affirming that (1) for construction contracts, the vendor is not in default on any monetary obligation owed to the State or a Political subdivision of the state, and (2) for all other contracts, that neither vendor nor any related party owe a debt as defined above and that neither Vendor nor any related party are in employer default as defined in the statute cited above unless the debt or employer default is permitted under the statute.

36. CONFLICT OF INTEREST: Vendor, its officers or members or employees, shall not presently have or acquire an interest, direct or indirect, which would conflict with or compromise the performance of its obligations hereunder. Vendor shall periodically inquire of its officers, members, and employees to ensure that a conflict of interest does not arise. Any conflict of interest discovered shall be promptly presented in detail to the Agency.

37. REPORTS: Vendor shall provide the Agency with the following reports identified by a checked box below:

Such reports as the Agency may request. Requested reports may include, but are not limited to, quantities purchased, agencies utilizing the contract, total contract expenditures by agency, etc.

Quarterly reports detailing the total quantity of purchases in units and dollars, along with a listing of purchases by agency. Quarterly reports should be delivered to the Agency.

38. BACKGROUND CHECK: In accordance with W. Va. Code § 15-2D-3, the State reserves the right to prohibit a service provider's employees from accessing sensitive or critical information or to be present at the Capital complex based upon results addressed from a criminal background check. The service provider is responsible for any costs associated with the fingerprint based state and federal background inquiry. Upon award the service provider shall submit a list of all persons who will be physically present and working at the Capitol complex to the Director of the Division of Protective Services for purposes of verifying compliance with this provision. The State reserves the right to prohibit a service provider's employees from accessing sensitive or critical information or to be present at the Capitol complex based upon results addressed from a criminal background check.

Service providers should contact the West Virginia Division of Protective Services by phone at (304) 558-9911 for more information.

DESIGNATED CONTACT: Vendor appoints the individual identified in this Section as the Contract Administrator and the initial point of contact for matters relating to this Contract.

Monmouth Solutions, Inc.

(Name, Title)

Anthony Farelli - Head of Sales

Anthony Farelli

(Printed Name and Title)

Anthony Farelli - Head of Sales

(Address)

93 Butman Road, Lowell, MA 01852

(Phone Number) / (Fax Number)

978 735 3968 anthony@monmouthsolutions.com

(E-mail address)

Monmouth Solutions
2024-09-25 13:29:06

CERTIFICATION AND SIGNATURE: By signing below, or submitting documentation through wvOASIS, I certify that I have reviewed this Solicitation in its entirety; that I understand the requirements, terms and conditions, and other information contained herein; that this bid, offer or proposal constitutes an offer to the State that cannot be unilaterally withdrawn; that the product or service proposed meets the mandatory requirements contained in the Solicitation for that product or service, unless otherwise stated herein; that the Vendor accepts the terms and conditions contained in the Solicitation, unless otherwise stated herein; that I am submitting this bid, offer or proposal for review and consideration; that I am authorized by the vendor to execute and submit this bid, offer, or proposal, or any documents related thereto on vendor's behalf; that I am authorized to bind the vendor in a contractual relationship; and that to the best of my knowledge, the vendor has properly registered with any State agency that may require registration.

By signing below, I further certify that I understand that this Contract is subject to the provisions of West Virginia code and rules and applicable adopted procedures; therefore, purchases and contracts violating West Virginia Code and rules are void and of no effect.

(Company)

Monmouth Solutions, Inc.

(Authorized Signature)

Representative Name, Title)

Anthony Farelli

Anthony Farelli, Head of Sales

(Printed Name & Title of Authorized Representative)

Anthony Farelli, Head of Sales

(Date)

9/25/2024 (978) 735-3968

(Phone Number) (Fax Number)

Monmouth Solutions

Monmouth Solutions
2024-09-25 13:30:40

ADDENDUM ACKNOWLEDGEMENT FORM

SOLICITATION NO.:

Instructions: Please acknowledge receipt of all addenda issued with this solicitation by completing this addendum acknowledgment form. Check the box next to each addendum received and sign below. Failure to acknowledge addenda may result in bid disqualification. Acknowledgment: I hereby acknowledge receipt of the following addenda and have made the necessary revisions to my proposal, plans and/or specification, etc.

Addendum Numbers Received:

(Check the box next to each addendum received)

Addendum No. 1

Addendum No. 6

Addendum No. 2

Addendum No. 7

Addendum No. 3

Addendum No. 8

Addendum No. 4

Addendum No. 9

Addendum No. 5

Addendum No. 10

I understand that failure to confirm the receipt of addenda may be cause for rejection of this bid. I further understand that any verbal representation made or assumed to be made during any oral discussion held between Vendor's representatives and any state personnel is not binding. Only the information issued in writing and added to the specifications by an official addendum is binding.

Monmouth Solutions, Inc. _____

Company _____

Anthony Farelli

Authorized Signature

9/25/2024

Date

Monmouth Solutions
2024-09-25 13:31:27

NOTE: This addendum acknowledgement should be submitted with the bid to expedite document processing.



202-205-8800 | sba.gov
409 3rd St, SW. Washington DC 20416

March 14, 2023

MONMOUTH SOLUTIONS, INC
SAM UEI: E474YENAVPB7
93 BUTMAN RD
LOWELL, MA 01852

Dear MONMOUTH SOLUTIONS, INC:

I am writing to inform you that MONMOUTH SOLUTIONS, INC has been certified by the Veteran Small Business Certification Program (VetCert) at SBA. Your certification confirms your eligibility to compete for set-aside contracting opportunities, as well as other benefits, as a Service-Disabled Veteran-Owned Small Business (SDVOSB).

What you need to know:

- MONMOUTH SOLUTIONS, INC is certified as a Service-Disabled Veteran-Owned Small Business (SDVOSB) and publicly listed at veterans.certify.sba.gov.
- Your certification is valid for three (3) years from the date of this letter.
- You may visit [SBA's website to download SBA-approved digital icons](https://sba.gov) that indicate your certification status.
- SBA may conduct a program examination at your office or work site during your certification period to verify the accuracy of your certification.
- You may apply for recertification 120 days prior to your expiration date by logging in to your Veteran Small Business Certification profile.

What to do if your business changes:

You must inform SBA of any changes to the business that could affect its eligibility for the program, such as:

- a closure
- a change to the firm's ownership, business structure, or control
- filing of a bankruptcy
- a change in a Veteran-owner's active duty status

You can inform SBA of changes through the VetCert website at veterans.certify.sba.gov. Failure to report eligibility changes within 30 days of the change could result in:

- Civil and criminal penalties
- A referral to the Debarment and Suspension Committee
- Decertification and removal from the Veteran Small Business Certification Program

Please keep a copy of this letter to confirm MONMOUTH SOLUTIONS, INC's continued program eligibility. Thank you for your service to our country and for continuing to serve the United States through small business ownership.

Sincerely,

John B. Perkins

John B. Perkins
Director Veteran Small Business Certification Program



All SBA programs and services are extended to the public on a nondiscriminatory basis.

Monmouth Solutions

PAST PERFORMANCE: EQUIPMENT

LIST INCLUDES NOTABLE CONTRACTS AND MONMOUTH'S PAST PERFORMANCE IS NOT LIMITED TO THIS LIST.

CONTRACT #12905B23Q0020

USDA ARS

CAT D8 DOZER RENTAL

VALUE: \$84,712.00

DATE: APRIL 2023

POC: lam.pham@usda.gov

CONTRACT #FA52152P0025

US AIR FORCE

RENTAL VEHICLES (NON-TACTICAL)

VALUE: \$198,000.00

DATE: SEPTEMBER 2023

POC: CHRISTIAN.OLIVIERI@US.AF.MIL

CONTRACT #W911S223P1484

US ARMY

RUBBER TRACKED CAT D1 DOZER

VALUE: \$218,873.00

DATE: JANUARY 2024

POC: craig.a.hall.civ@army.mil

UEI: E474YENAVPB7

CAGE: 9DMG0

SDVOSB CERT #: VSBC-52457208749



Monmouth Solutions

PAST PERFORMANCE: EQUIPMENT

LIST INCLUDES NOTABLE CONTRACTS AND MONMOUTH'S PAST PERFORMANCE IS NOT LIMITED TO THIS LIST.

CONTRACT #W912CN24P0003

US ARMY

(2) 135' ARTICULATING BOOM LIFT RENTAL

VALUE: \$35,000.00

DATE: FEBRUARY 2024

POC: Travis.C.Tonini.civ@army.mil

CONTRACT #FA445223P0014

US AIR FORCE

RENTAL VEHICLES (NON-TACTICAL)

VALUE: \$156,030.00

DATE: JULY 2023

POC: BROOKE.CULTRA.1@US.AF.MIL

CONTRACT #B2317225

CITY OF PHILADELPHIA, PA

OFFICE CONTAINER AND 500KW GENERATOR RENTAL

VALUE: \$10,000.00

DATE: MAY 2023

POC: JOSEPH.J.LYNCH@PHILA.GOV

UEI: E474YENAVPB7

CAGE: 9DMG0

SDVOSB CERT #: VSBC-52457208749

